

## Cellular RADIONOVA® M10259 RF Antenna Module

Antenova's Cellular RADIONOVA RF Antenna Module is the industry's first RF antenna module targeting GSM and GPRS applications. It covers GSM850/900 and DCS/PCS frequencies. The Cellular RADIONOVA RF Antenna Module integrates a high performance RF front end with Antenova's high efficiency quad-band HDA® antenna in the same package. The highly integrated module offers optimum performance, even under loaded conditions. The module can be installed inside a mobile phone, PDA or other handheld device with minimal or no customization.

Cellular RADIONOVA offers the greatly reduced design time and faster time-to-market advantages of a platform approach. Cellular RADIONOVA RF antenna modules combine a high power, high efficiency RF module for GSM/GPRS operation with an antenna switch and filter. Further customized integration is possible with the inclusion of a transceiver IC for full quad-band RF circuitry integrated with the antenna in a single module. The RF circuitry is complemented with Antenova's patented high efficiency HDA antenna that offers exceptional RF performance.

### Benefits:

- Low cost single package RF Antenna Module
- Easy to use 'drop-in' solution
- Reduced real estate requirements
- Low volume and small size package

### RF Features - GSM

- High power and efficiency
- GPRS capable (Class 12)
- Power control range >50dB
- Integrated Power Control Scheme

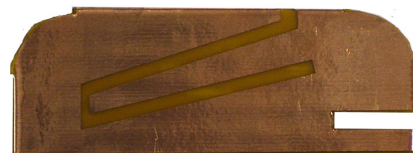
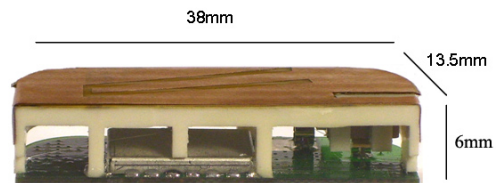

Top View

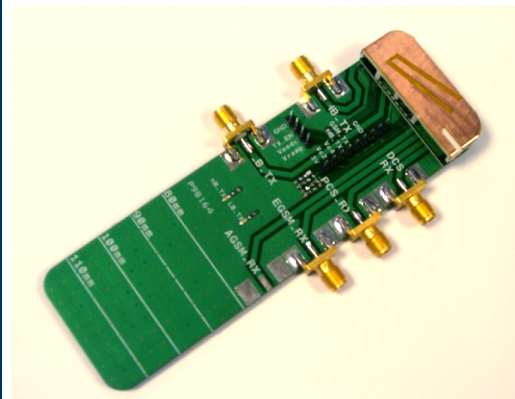

Cellular RADIONOVA  
Testboard

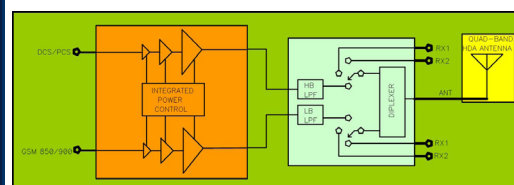

Block Diagram

# Cellular RADIONOVA® M10259 RF antenna module

## electrical

Frequency Ranges:	GSM850, GSM900, DCS1800, PCS1900
Supply Voltage:	3.5V
Output Power at Antenna:	GSM = 33dBm, DCS/PCS = 31dBm
Antenna Radiation Efficiency:	60%
Impedence:	50Ω unbalanced feed
Temperature:	-40°C to +85°C

## mechanical

Dimensions:	13.5 x 38 x 6mm
Volume:	3.5cc
Mounting:	Surface mount
Groundplane:	38 x 90mm

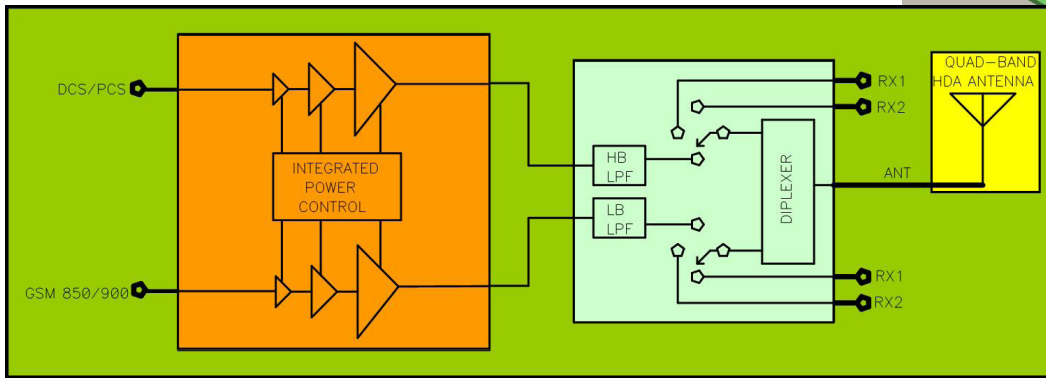
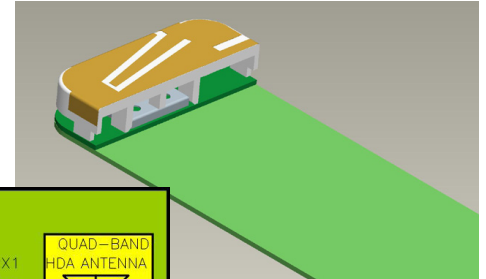

Block Diagram

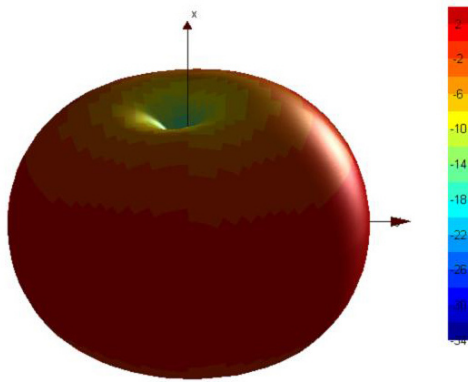

Total Polarization [dBi] 890MHz

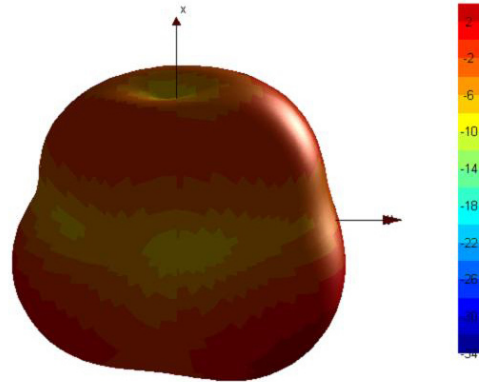

Total Polarization [dBi] 1850MHz



Certificate No: 4598



Antenova Limited • Far Field House • Albert Road • Stow-cum-Quy • Cambridge • CB5 9AR • UK  
 t: +44 (0)1223 810600 f: +44 (0)1223 810650  
 info@antenova.com • www.antenova.com

UK Patent Applied for  
 Version 4, released 08 February 2009  
 The information provided in this document was correct at the time of going to print